

TAIE

www.fa-taie.com
www.fa-taie.com.tw

High New Feeling!

First White LED Module in the world

Outstanding Excellent Top Elegance

FY

Digital PID Temperature Controllers / Process Controllers

High Quality High Reliability



BEST CHOICE FOR PROCESS AND TEMPERATURE CONTROL

Application: Control temperature, humidity, pressure, flow and PH.

FY series controllers are microprocessor based controllers. Which have been designed with high accuracy input, various output selection, useful options and good reliability at a competitive price.

FY series use "PID+FUZZY" algorithm to implement excellent control. The output status is displayed on the built in "Bar-Graph" display.

FY series not only provide the basic control output selections but also plus advanced options such as "Motor Valve Control", "SCR/TRIAC Trigger", and "Programmable RAMP/SOAK".

FY series support MODBUS protocol. Communication with HMI is more convenient. New additional HBA function with competitive price, user can upgrade system safety easy.

Add functional Module stand & jumper, supply customer easy to change Relay SSR.4~20mA/TC.DPT100. Add new white LED module break the traditional vision, opening the new LED century.

Available in 4 sizes, the models and sizes are as below:

- FY401 : 48X48mm (DIN 1/16)
- FY801 : 48X96mm (DIN 1/8)
- FY701 : 72X72mm (DIN 3/16)
- FY901 : 96X96mm (DIN 1/4)

Available in 7 sizes, the models and sizes are as below:

- FY400 : 48X48mm (DIN 1/16)
- FY600/800 : 48X96mm (DIN 1/8)
- FY700 : 72X72mm (DIN 3/16)
- FY900 : 96X96mm (DIN 1/4)
- FY100 : 175X110mm
- FY101 : 90X90mm



FY401
FY701
FY801
FY901
FY600
FY400
FY700
FY800
FY900

<p>CE Approval & free power</p> <p>All models get CE approval. Operate on any voltage from AC 85~265V at 50/60Hz. DC 24V is also available(optional function).</p>	<p>IP65 Proof</p> <p>IP65 dust & water proof is available for all models(optional function).</p>
<p>Heater Break Alarm (HBA)</p> <p>(Heater Break Alarm) Heater current flowing through CT can be displayed on controller. If heater current is less than HBA set value,AL1 will be activated (optional function).</p>	<p>MODBUS Communication</p> <p>HMI Controller FY series suport both MODBUS RTU and MODBUS ASCII protocol. Communication between controller and HMI or other equipment is more convenient(optional function).</p>
<p>Autotuning (AT)</p> <p>AT Function can calculate the optimize PID value for your control system,without trying</p>	<p>Auto/Manual mode</p> <p>Conveniently switched between auto/manual output mode by clicking "A/M" key(except "FY400/FY401").</p>
<p>Various Indication Lamps</p> <p>Real time monitor the status of output(OUT1/OUT2),AT,alarm (AL1/AL2/AL3),manual output (MAN) and program(PRO).</p>	<p>Bar-Graph</p> <p>Output percent displayed on the bar-graph in 10 LEDs resolution(except "FY400/FY401").</p>
<p>High Accuracy</p> <p>Input with 14bit A/D resolution,0.2% accuracy of FS. Built in "AutoZero-AutoSpan" function keep good accuracy.</p>	<p>Data Lock Function</p> <p>All parameters are seperated in 3 operation levels. Each parameter can be hidden or locked to prevent unauthorized changes.</p>

Various I/O Types



Peripheral Options

Remote SV

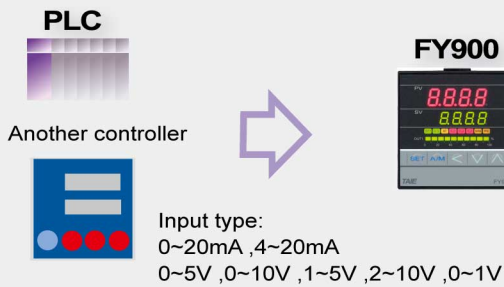

Transmission



Communication (RS485 Communication) MODBUS Protocol

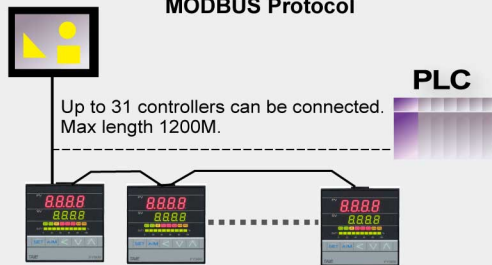

Communication (TTL Communication)

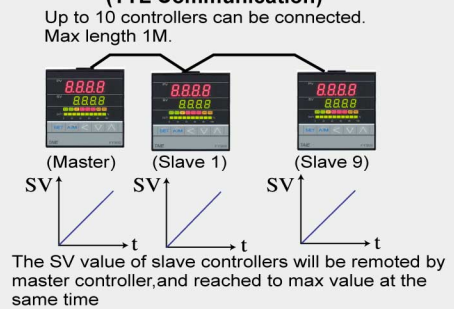

Special Application

Ramp/Soak Program

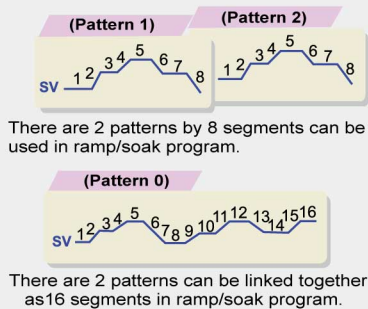

Heating and Cooling Control

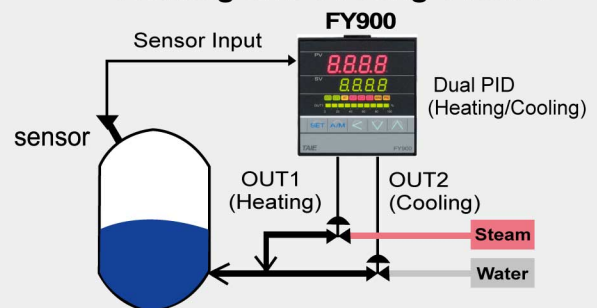

Motor Valve Control

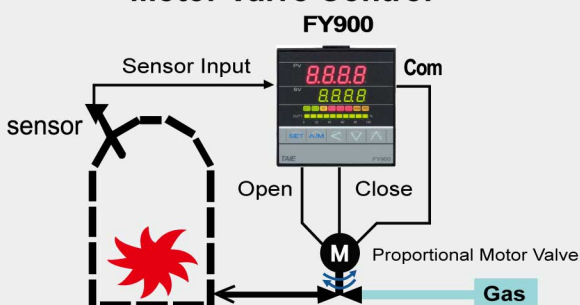

SCR/TRIAC Trigger

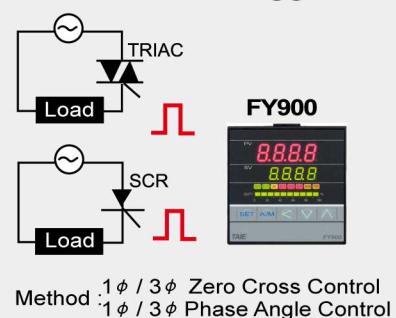

Easy to change Relay/SSR/4~20mA 3 types of OUTPUT



EX: Relay → SSR

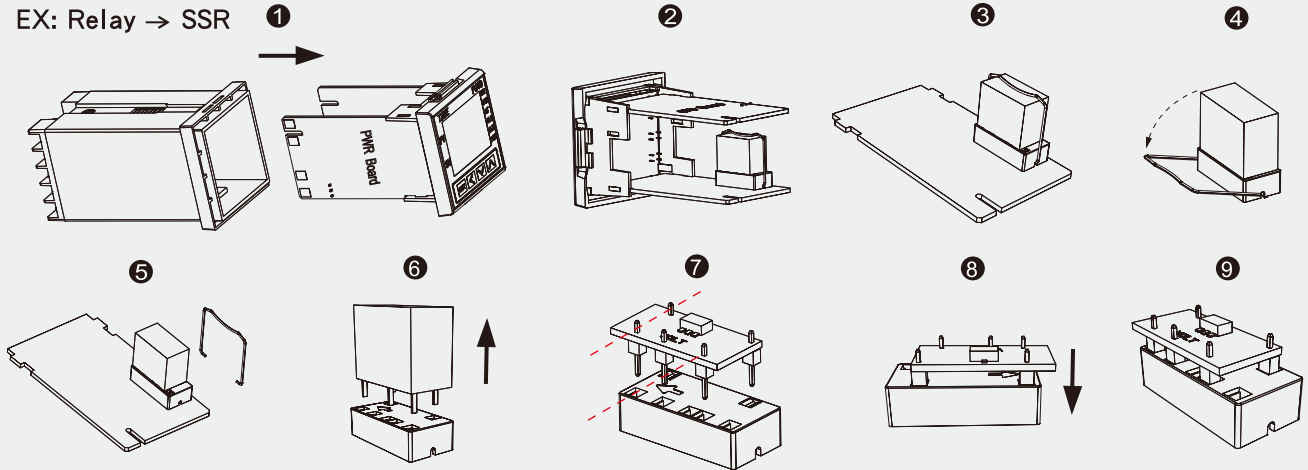

1. Pull controller out from the case.
2. Turn controller to see the module stand.
3. Relay Module has a spring clip to lock it.
4. Take the spring clip to left.
5. Open the spring clip to show Relay.
6. Pull the Relay out.
7. Insert SSRdrv Module. (The front of two aperture is parallel)
8. Insert the module gently than push down to the base.
9. Make sure it's bilateral. (Volt & mA Module don't need spring clip)

Input Type Change of TC ↔ RTD

Convenient Installation

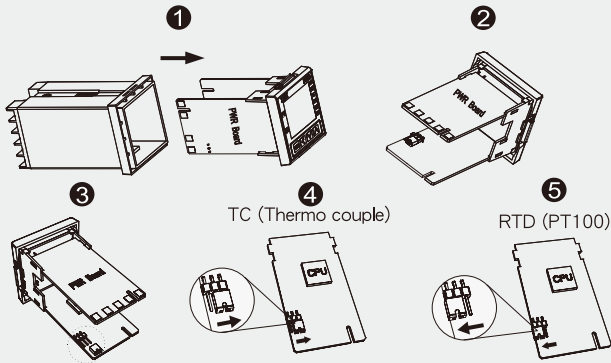

1. Take out the main body from outer case: adjust the jumper to the correct place
2. Start power after setting jumper to the correct place
3. Amend the input type from the front membrane to enter in Level 3 to set.
4. Please be sure to cut off power and start again after amending input type so that the new parameters could be effective.
5. To change input type of TC or RTD is available but linear input is unavailable. Please ask our local distributor for help.

New High Light LED Module Display

Provide Red & white light to choose



To mount panel easily

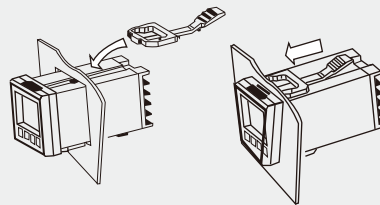

Excellent Control

Fuzzy Logic

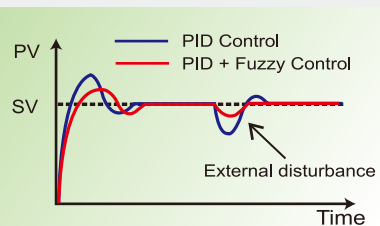

Built in fuzzy logic suppress the overshoot due to SV changes or external disturbance.

Autotuning (AT)

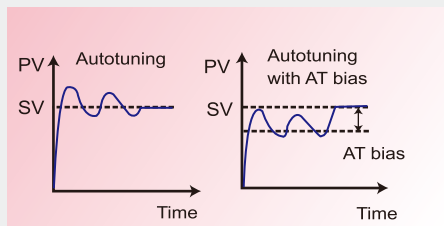

When autotuning acts, it will make PV hunting 1~2 cycle to calculate optimize PID value. To protect user's device, FY series controller can perform PV hunting below SV by setting AT bias value (ATVL).

Limit Setting

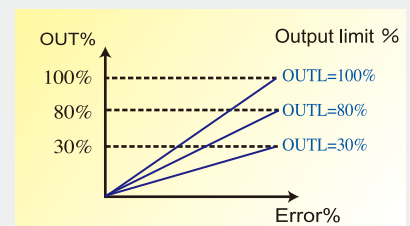

Built in output limit function. Use this function to get different gradient output and set limit for output.

Parts Description

FY400 (Red light)
FY401 (White light)

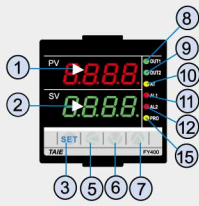

FY600 (Red light)

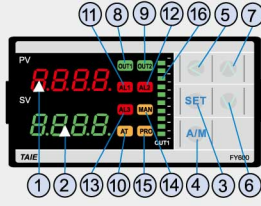

FY800 (Red light)
FY801 (White light)

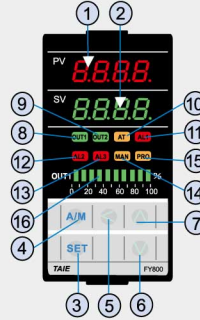

FY700/900 (Red light)
FY701/901 (White light)

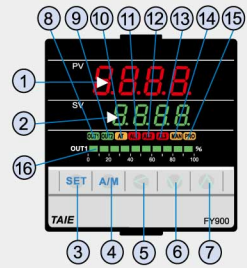

SYMBOL	NAME	FUNCTION	SYMBOL	NAME	FUNCTION
PV	① Measured value (PV)display	Displays PV or various parameter symbols(Red)	OUT1	⑧ OUT1 lamp	Lights when OUT 1 is on(Green)
SV	② Setting value (SV)display	Displays SV or various parameter values(Green)	OUT2	⑨ OUT2 lamp	Lights when OUT 2 is on(Green)
SET	③ Set Key	Used for parameter calling up and set value registration	AT	⑩ Autotuning lamp	Lights when Autotuning is activated(Orange)
A/M	④ Auto/Manual key	Switches between Auto(PID) output mode and Manual output	AL1	⑪ Alarm 1 lamp	Lights when Alarm 1 is activated(Red)
<	⑤ Shift Key	Shift digits when settings are changed	AL2	⑫ Alarm 2 lamp	Lights when Alarm 2 is activated(Red)
∨	⑥ Down Key	Decrease numbers (*Only for programmable controller)	AL3	⑬ Alarm 3 lamp	Lights when Alarm 3 is activated(Red)
∧	⑦ Up Key (*Program Run)	Increase numbers (*Only for programmable controller)	MAN	⑭ Manual output lamp	Lights when manual output is activated (Orange)
			PRO	⑮ *Program Running lamp	*Flashes when program running (Only for programmable controller)
			OUT1%	⑯ Output 1% Bar-Graph display	Output 1% is displayed on 10-dot LEDs

External Dimension

Unit : mm

<p>FY400 (Red light) FY401 (White light)</p>			<p>Terminal Cover (Option) NEW</p>	
<p>FY600 (Red light)</p>			<p>Terminal Cover (Option)</p>	
<p>FY700 (Red light) FY701 (White light)</p>			<p>Terminal Cover (Option)</p>	
<p>FY800 (Red light) FY801 (White light)</p>			<p>Terminal Cover (Option)</p>	
<p>FY900 (Red light) FY901 (White light)</p>			<p>Terminal Cover (Option)</p>	
<p>FY100 FY101 (Require KA601 External Operating Box)</p>				

Terminal Arrangement

FY / FY1 Series

Digital PID Controller

FY400 (Red light) / FY401 (White light)

A. Power Supply

AC 85-265V
DC 15-50V(Option)

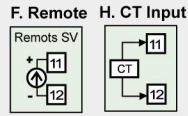
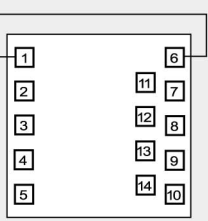

B. Control Output

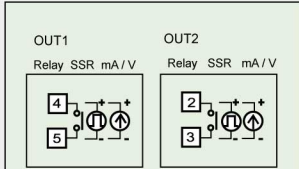

C. Input

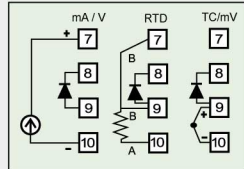

D. Alarm

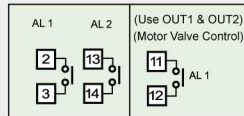

E. Transmission G. Communication

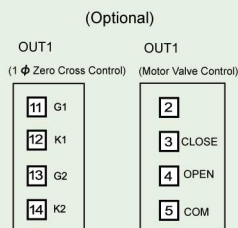
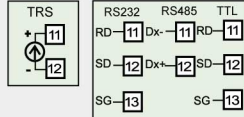

FY700 (Red light) / FY701 (White light)

A. Power Supply

AC 85-265V
DC 15-50V(Option)

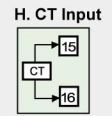
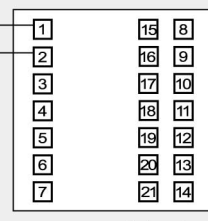

B. Control Output

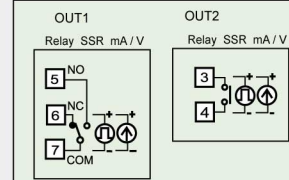

C. Input

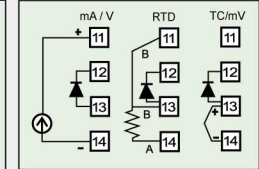

D. Alarm

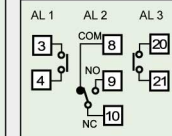

E. Transmission

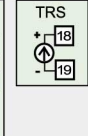

(Optional)

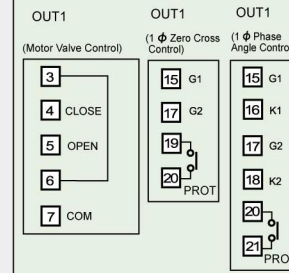

G. Communication

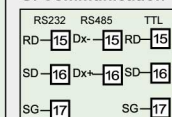

F. Remote

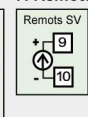

FY600.800 (Red light) / FY801 (White light)

A. Power Supply

AC 85-265V
DC 15-50V(Option)

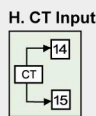
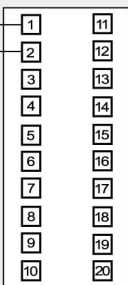

B. Control Output

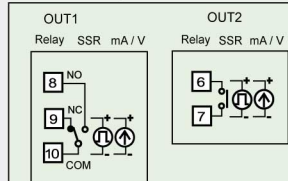

C. Input

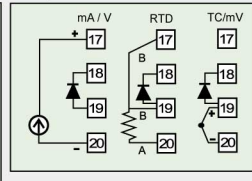

D. Alarm

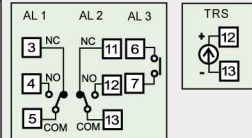

G. Communication

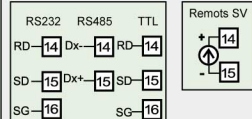

E. Transmission

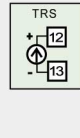

F. Remote

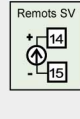

FY900 (Red light) / FY901 (White light)

A. Power Supply

AC 85-265V
DC 15-50V(Option)

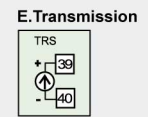
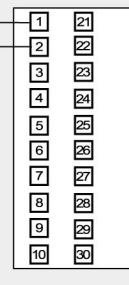

H. CT Input

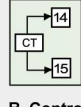

F. Remote

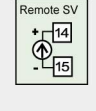

B. Control Output

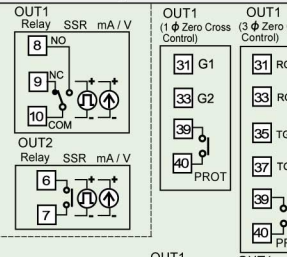

C. Input

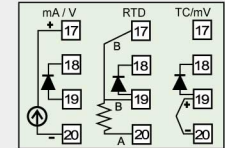

D. Alarm

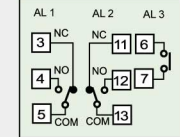

G. Communication

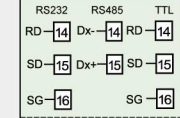

FY100

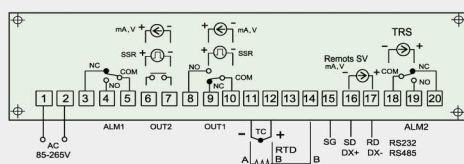

FY101

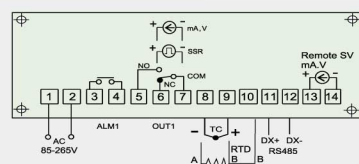

When AL3 Function enable, RS485 Function move to Alarm board.

Specifications

FY / FY1 Series

Digital PID Controller

※ FY400, FY600, FY700, FY800, FY900 Red light Series / FY401, FY701, 801, FY901 White light Series

Standard Spec.

Model	FY400/401	FY600	FY700/701	FY800/801	FY900/901	FY100	FY101
Dimension	48X48mm	96X48mm	72X72mm	48X96mm	96X96mm	175X110mm	90X90mm
LED Display(PAT.)	high light technology, Red/Green/Orange with in one Module					Require KA601 External Operating Box	
Supply voltage	AC 85~265V , DC24V (Optional)					AC 85~265V	
Frequency	50/60 HZ						
Power Consumption	approx 4VA						
Memory	Non-volatile memory E ² PROM						
Input	Accuracy : 0.2%FS, Sample time : 250ms						
TC	K , J , R , S , B , E , N , T , W5Re/W26Re , PL2 , U , L						
RTD	DPT100 , JPT100 , JPT50						
mA dc	4~20mA , 0~20mA						
Voltage dc	0~1V , 0~5V , 0~10V , 1~5V , 2~10V -10~10mV , 0~10mV , 0~20mV , 0~50mV , 10~50mV						
DP Position	0000 , 000.0 , 00.00 , 0.000 (available for mA or Voltage dc input)						
Output 1	Main control output						
Relay	SPST type			SPDT type			
	3A , 220V , electrical life : 100,000 times or more(under the rated load).						
Voltage Pulse	For SSR drive. ON:24V , OFF:0V , maximum load current:20mA.						
mA dc	4~20mA , 0~20mA .Maximum load resistance:560 Ω						
Voltage dc	0~5V , 0~10V , 1~5V , 2~10V. Maximum load current:20mA.						
Alarm 1	SPST type	SPDT type	SPST type	SPDT type		SPST type	
	3A , 220V , electrical life : 100,000 times or more(under the rated load).						
Control algorithms	PID , P , PI , PD , ON/OFF(P=0) , FUZZY						
PID range	P:0~200% , I:0~3600 Secs , D:0~900 Secs						
Isolation	Output terminal (control output , alarm ,transmission) and Input terminal are isolated separately.						
Isolated resistance	10M Ω or more between input terminals and case(ground) at DC 500V 10M Ω or more between output terminals and case(ground) at DC 500V						
Dielectric strength	1000V AC for 1 minute between input terminals and case(ground) 1500V AC for 1 minute between output terminals and case(ground)						
Operating temperature	0~65°C / 0~50°C						
Humidity range	20~90% RH						
Weight (approx)	approx 150g	approx 225g			approx 300g	approx 130g	approx 80g

Optional Spec.

Model	FY400/401	FY600	FY700/701	FY800/801	FY900/901	FY100	FY101
RAMP/SOAK Program	2 Patterns with 8 segments each . The 2 patterns can be linked together as 16 segments use						
Output 2	For heating and cooling control use						
Relay	SPST type						
Voltage Pulse	For SSR drive. ON:24V , OFF:0V , maximum load current:20mA.						
mA dc	4~20mA , 0~20mA .Maximum load resistance:560 Ω						
Voltage dc	0~5V , 0~10V , 1~5V , 2~10V. Maximum load current:20mA.						
Alarm 2	SPST type	SPDT type				SPST type	
Alarm 3	None	SPST type					
Heater Break Alarm (HBA)	Display Range of Heater Current:0.0~99.9A , Accuracy : 1%FS Included CT :SC_80_T (5.8mm dia , 0.0~80.0A) or SC_100_T(12mm dia , 0.0~99.9A) Alarm Relay : AL1						
Transmission	Available for PV or SV transmission						
mA dc	4~20mA , 0~20mA. Maximum load resistance : 560 Ω						
Voltage dc	0~5V,0~10V,1~5V,2~10V. Maximum load current : 20mA.						
Remote SV Input	4~20mA , 0~20mA , 0~5V , 0~10V , 1~5V , 2~10V are available						
Communication	Protocol : MODBUS RTU,MODBUS ASCII, TAIE Interface : RS232 , RS485 , TTL Baudrate : 38400 , 19200 , 9600 , 4800 , 2400 bps. 8 bit , Start bit : 1 bit , Parity : Odd or Even , Stop bit : 1 or 2 bit						
WaterProof/DustProof	IP65					None	None

Model & Suffix codes

Model	Output1	Output2	Alarm	TRS	Remote SV	Communi- cation	Input Type	Power	Accessories
FY400 (Red light) FY401 (White light)	1	0	1	0	0	0	02	A	N
FY400/401 48x48mm	0 None	0 None	0 None	0 None	0 None	0 None	See Input Codes	A AC 85~265V	N None
FY600 96x48mm	1 Relay	1 Relay	1 1 Set	1 4~20mA	1 4~20mA	1 4~20mA		D DC 24V	T Terminal Cover
FY700/701 72x72mm	2 Voltage Pulse (SSR Drive)	2 Voltage Pulse (SSR Drive)	2 2 Sets	2 0~20mA	2 0~20mA	2 0~20mA	3 TTL	B Board Type AC85~265V pluggable terminal block	W IP65
FY800/801 48x96mm	3 4~20mA	3 4~20mA	3 3 Sets	A 0~5V	A 0~5V	A 0~5V			A RS232_MODBUS
FY900/901 96x96mm	4 0~20mA	4 0~20mA	A HBA*	B 0~10V	B 0~10V	B 0~10V	B RS485_MODBUS		
Board Type	5 1 φ SCR zero cross control	5 1 φ SCR zero cross control	B HBA+AL2	C 1~5V	C 1~5V	C 1~5V			
FY100 175x110mm	6 3 φ SCR zero cross control	6 3 φ SCR zero cross control	C HBA+AL2+AL3	D 2~10V	D 2~10V	D 2~10V			
FY101 90x90mm (STANDARD)	A 0~5V	A 0~5V							
PFY400/401 48x48mm	B 0~10V	B 0~10V							
PFY600 96x48mm	C 1~5V	C 1~5V							
PFY700/701 72x72mm	D 2~10V	D 2~10V							
PFY800/801 48x96mm	7 Motor valve control	7 Motor valve control							
PFY900/901 96x96mm	8 1 φ SCR phase angle control	8 1 φ SCR phase angle control							
Board Type	9 3 φ SCR phase angle control	9 3 φ SCR phase angle control							
PFY100 175x110mm									
PFY101 90x90mm (RAMP/SOAK Programmable)									

* : Block means optional functions with additional charge
* HBA : Heater Break Alarm(HBA must use AL1 as alarm relay)

Combination of options and models

Options	RAMP/SOAK PROGRAM	Output 1					Output2	Alarm2	Alarm3	HBA	Transmission	Remote SV	Communication	DC 24V Power
		1 φ SCR_Z	3 φ SCR_Z	Motor valve control	1 φ SCR_P	3 φ SCR_P								
FY400/401	○	○	-	○	-	-	○	○	-	○	○	○	○	
FY600	○	-	-	○	○	-	○	○	○	○	○	○	○	
FY700/701	○	○	-	○	-	-	○	○	○	○	○	○	○	
FY800/801	○	-	-	○	-	-	○	○	○	○	○	○	○	
FY900/901	○	○	○	○	○	○	○	○	○	○	○	○	○	
FY100	○	-	-	○	-	-	○	○	○	○	○	○	-	
FY101	○	-	-	○	-	-	○	○	○	○	○	○	-	

○ Available - Not available

* Remote SV function is not available, if HBA Function has been specified.

Input type table

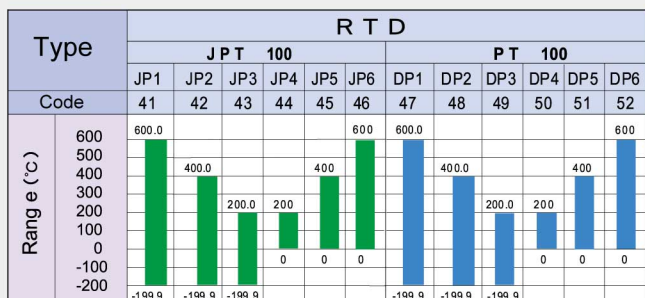
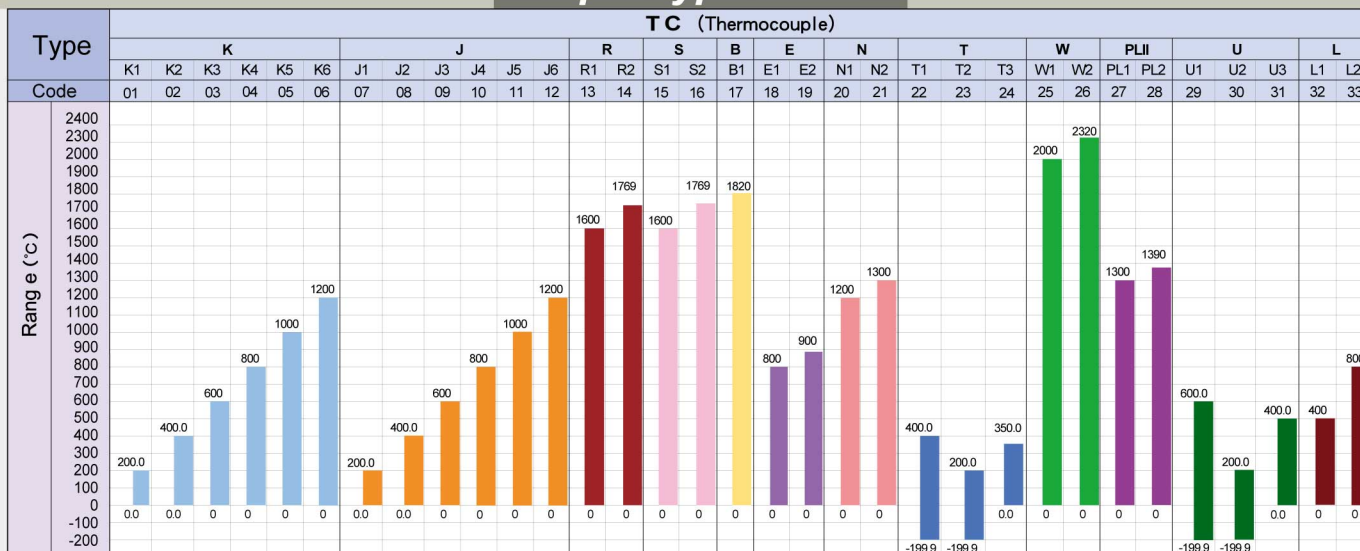

Type	LINEAR					
Code	AN1		AN2		AN3	
	61	62	63	64	71	76
RANGE	-10~10mV		-2~2V		-5~5V	
	-10~10V		0~10mV		0~20mV	
	Four Kinds of choices: -1999-9999 -199.9-999.9 -19.99-99.99 -1.999-9.999					

Type	LINEAR											
Code	AN4					AN5						
	81	82	83	84	85	86	87	91	92	93	94	
RANGE	0~50mV		0~20mA		0~1V		0~5V		0~10V		0~5KΩ	
	0~2V		10~50mV		4~20mA		1~5V		2~10V			
	Four Kinds of choices: -1999-9999 -199.9-999.9 -19.99-99.99 -1.999-9.999											